

READ AND SAVE THESE INSTRUCTIONS

**calorex**

**Evaporative  
Humidifier**

**Century Series 4**

# OWNERS CARE & USE MANUAL

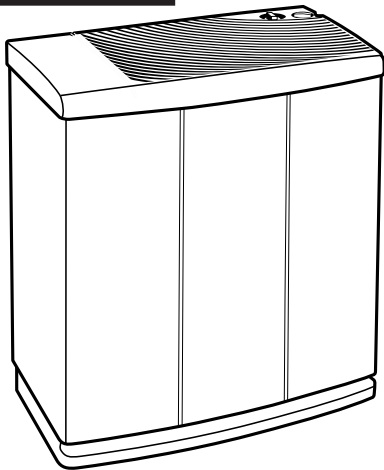

## **Models:**

H12C UKO

H12C EUO

- Easiest to Fill
- Easiest to Clean
- Quiet Setting for Nighttime Use
- Automatic Humidistat
- Automatic Shutoff

230 V a.c. 50 Hz 0.65 A

Noise Level, Niveau de bruit  
Nivel de ruido, geräuschpegel

57 dB (A)

**CE**

French, Spanish and  
German instructions  
included.

Directives en français,  
espagnol et  
allemand comprises.

Se incluyen instrucciones  
en Español, Francés y  
Alemán.

Mit deutsche,  
französische und  
spanische  
Gebrauchsanweisung.



Printed in U.S.A

© 2003 586 0740

# Important Safeguards

## READ BEFORE USING YOUR HUMIDIFIER

- 1) Do not place the cord under rugs, in traffic areas, or near heat sources.
- 2) Do not use the humidifier if the cord is damaged.
- 3) Always unplug the power cord before cleaning, servicing, or when the unit is not in use.
- 4) Do not place the humidifier near loose curtains, combustible materials, or heat-producing objects.
- 5) Regular cleaning is recommended. Refer to the CARE & MAINTENANCE section in this manual.
- 6) It is very important that cleaning solutions and other liquids (such as bleach) which may be used to clean the cabinet are not sprayed or applied to the power pack/chassis assembly. These cleaning solutions can cause a serious electrical malfunction of the humidifier.

## Introduction

Your humidifier adds invisible moisture to your home by moving dry inlet air through a saturated wick. As air moves through the wick, the water evaporates into the air, leaving behind any white dust, minerals, or dissolved and suspended solids. Because the water is evaporated, there is no messy mist or spray and no white dust, just clean and invisible moist air. As the wick traps accumulated materials from the water, its ability to absorb and evaporate water decreases. We recommend changing the wick at least once a year, preferably disposing of the used wick at the end of the humidifying season and starting with a new wick at the beginning of the next humidifying season. In hard water areas, more frequent replacement may be necessary to maintain your humidifier's efficiency.

**CAUTION - We recommend Bacteria Treatment whenever you refill the water bottles to eliminate bacteria growth. Follow the directions to determine the proper amount to be added to the 9.5-Litre. water bottle.**

The wick does not require the use of chelating agent-type water treatments that are intended for use in Rotobelt or waterwheel-type humidifiers.

# Important Filling Information

- 1) Your humidifier is equipped with one water bottle. When both the water bottle and reservoir have emptied, the humidifier fan will automatically shut off, but will start again automatically when the water bottle and reservoir are refilled.
- 2) When the bottle is being filled for the first time and the wick is still dry, it will take approximately 20 minutes to drain the bottle into the reservoir. After the bottle has emptied into the reservoir, it should be refilled again to obtain maximum running time.
- 3) When refilling the bottle and the wick is still wet, it will take approximately 12 minutes to refill the reservoir. At this time, you should refill the bottle for maximum running time.
- 4) Dry air is drawn into the humidifier through the back and moisturized as it passes through the evaporative wick. It is then fanned out into the room.

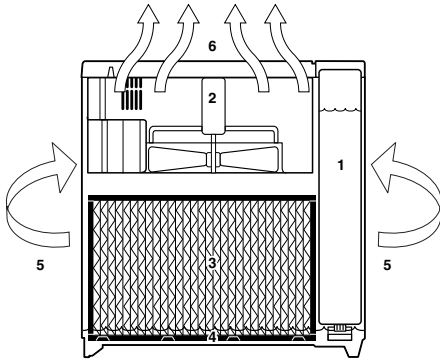

- 1) Water bottle
- 2) Chassis/Power Pack  
(motor and fan assembly)
- 3) Evaporative wick
- 4) Water reservoir
- 5) Dry room air intake
- 6) Moist air output

- 5) Locate your humidifier on an inside wall near an electrical outlet. The humidifier should be at least 10 cm away from the wall for best results. Do not position the unit directly in front of a hot air duct or radiator.

# Assembly and Operation

- 1) Remove the two polyfoam inserts from the top of the humidifier.
- 2) Lift off the black water bottle cover (left-hand side). Remove the water bottle, lift off the chassis/power pack and then remove the humidifier cabinet from the carton.
- 3) Remove the evaporative wick, float assembly (black rod with white float), and all of the remaining packaging materials from the cabinet. Check to see that you have all of the following items removed from the boxed accessory kit and cabinet before discarding the packaging:
  - Filler hose
  - Castor kit
  - Water bottle with cap.

# ASSEMBLY

## CASTORS

- 4) Turn the emptied cabinet upside down. Insert each castor stem into the four castor holes in each corner of the humidifier bottom. The castors should fit snugly and be inserted until the stem shoulder reaches the cabinet surface. Do not force. **A.**
- 5) Turn the cabinet right side up.

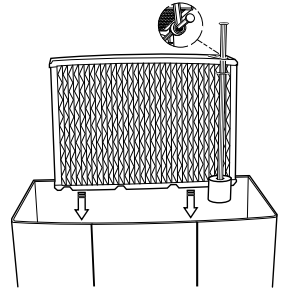

## EVAPORATIVE WICK

- 6) When placing the wick back into the humidifier, the rod and float assembly must also be reattached. Insert the top of the float rod through the hole on the extended wick retainer (attached to the top of the wick frame) **(A)**. Holding the float in place, lower the wick and float assembly together into the cabinet. The wick has a mounting rib on the top edge which hooks over a rib at the inside back of the cabinet. The white float must be positioned into the pocket in the bottom of the cabinet. **(B)**

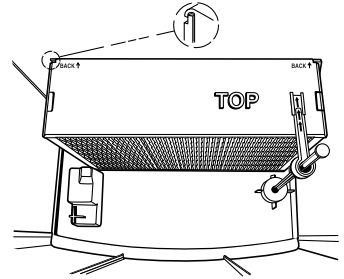

## AIR CLEANING FILTER (OPTIONAL)

- 7) The AirCare filter has four tabs that engage into four keyhole slots that mount the AirCare filter onto the outside of the back of the cabinet. **(C)**

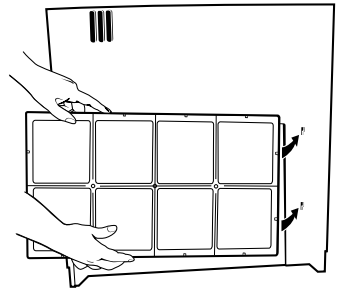

## CHASSIS/POWER PACK

- 8) Place the chassis/power pack unit into the cabinet, so it fits without tipping or rocking.

## BOTTLE

- 9) Fill the bottle with cool, fresh (preferably unsoftened) water. If you only have softened water available in your home, you can use it, but you will notice a buildup of minerals on the wick much sooner. **D.**

The bottle holds 9.5 litres. When filling, be careful not to pressurize it by overfilling. Bottle damage can result from this. A fill hose is provided with your humidifier which will fit most taps **Place the water bottle into the**

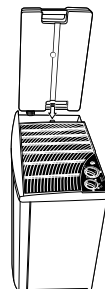

**left side of the humidifier with the valve cap end down, so that the groove in the water bottle faces the inside. (D)**

Replace the black water bottle cover, and this will complete assembly.

Do not attempt to move a filled humidifier as the water in the reservoir will spill out the rear grille opening. Empty the unit before relocating.

**Note: for optimum running time, fill the water bottle, tighten the cap, and place inside unit, allowing it to completely drain into the water reservoir. This may take up to a half hour. Then refill the bottle and replace in cabinet. Do not fill the reservoir with a bucket, as overfilling will result in water damage. Use only the bottle provided.**

- 10) We recommend using Bacteria treatment whenever you refill the water bottle to eliminate bacterial growth. Add bacteriostat according to the instructions on the bottle and then tighten the valve cap on your water bottle.

## OPERATION

- 11) Plug cord into wall socket. Your humidifier is now ready for use. Position the unit at least 10 cm from the wall for best results.
- 12) The 3-speed fan control allows you to use a low setting for the most quiet operation or a high setting for maximum output.
- 13) All models have an automatic humidistat. The humidistat will turn the humidifier on when the relative humidity in your home is below the humidistat setting and will turn the humidifier off when the relative humidity reaches the humidistat setting. For initial operation, set the humidistat at the "two-droplet" position and adjust up or down from there to achieve the desired humidity level.
- 14) The refill light will indicate when the unit is completely out of water. The motor will also shut off. To refill the unit, see Step 9.

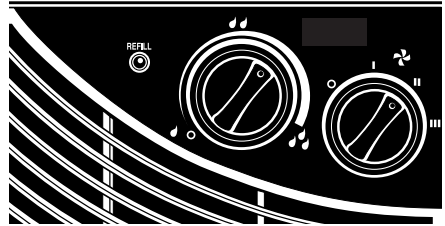

## Optional AirCare<sup>®</sup> Filter

The first stage of the air filter is 3M Filtrete<sup>™</sup>, a high-efficiency, electrostatically charged filter media which traps dust, pollen, and airborne pollutants. The second stage of the AirCare filter is an activated carbon media which absorbs odors from cooking, pets, or tobacco smoke. We recommend replacing the AirCare filter at least once a year, and more often if necessary. When the white filter media is coated with a layer of dust and dirt, it is time to replace the AirCare filter.

The certified water output of your humidifier will be reduced when using the AirCare filter.

AirCare filters are optional and are not required for normal operation of the humidifier.

*FILTRITE<sup>™</sup> is a trademark of 3M Corp.*

# Care and Maintenance

**IMPORTANT: We recommend cleaning your humidifier every two weeks. Follow instructions.**

Humidifiers provide comfort by adding moisture to dry, heated indoor air. To get the most benefit from the humidifier and to avoid product misuse, follow all instructions carefully, specifically the operation and care and maintenance guidelines. Please note this is an electrical appliance and requires careful attention when in use.

In addition, if you do not follow the recommended care and maintenance guidelines, microorganisms may be able to grow in the water within the humidifier's reservoir.

**Caution: Disconnect power before cleaning or servicing unit.**

**WARNING: It is very important that cleaning solutions, such as bleach, bacteria treatment, or descaler which could be used to clean the cabinet are not sprayed or applied to the chassis/power pack assembly. Additionally, do not immerse the power pack in water or any other solution. These solutions can cause a serious electrical malfunction of the humidifier.**

- 1) Turn unit off by turning humidistat completely counterclockwise.
- 2) Unplug electrical cord from wall socket.
- 3) Lift out water bottle.
- 4) Lift off chassis/power pack.
- 5) Carefully lift wick with rod and float assembly from cabinet, allowing any water to drain from it into cabinet reservoir. Then remove float assembly from wick.

## REMOVING SCALE FROM THE CABINET

- 6) Remove any remaining water in the reservoir with a sponge. Fill the reservoir with 3.8 litres of fresh warm water and 250 ml of undiluted white vinegar. Let solution stay 20 minutes. Clean all interior surfaces with soft brush. Dampen soft cloth with undiluted white vinegar and wipe out the reservoir to remove scale.
- 7) Rinse the reservoir thoroughly with water to remove scale and cleaning solution before disinfecting.

## DISINFECTING CABINET RESERVOIR

- 8) Fill the reservoir with a mixture of 5 ml chlorine bleach and 3.8 litres of fresh warm water. Let solution stay 20 minutes, swishing every few minutes. Make sure the cleaning solution does not come in contact with the chassis/power pack. Do not attempt to pour liquid directly through the grille into the humidifier cabinet.
- 9) Empty the reservoir after 20 minutes. Rinse with water until bleach smell is gone. Dry with clean cloth or paper towel.
- 10) Clean all surfaces of the chassis/power pack with a soft, dry cloth. **DO NOT USE LIQUID CLEANING SOLUTIONS, INCLUDING WATER, TO CLEAN THE CHASSIS/POWER PACK. AN ELECTRIC SHOCK MAY RESULT OR THE HUMIDIFIER MAY BE DAMAGED.**

## **DISINFECTING THE BOTTLE**

- 11) Remove the water bottle cap and empty remaining water into a drain. pour a mixture of 450 ml of water and 28.5 ml of household bleach into the bottle. replace cap and shake bottle thoroughly. Remove cap, drain bottle into sink, rinse well with fresh water.

## **RE-ASSEMBLE THE UNIT**

- 12) Replace the wick with rod and float assembly into water reservoir, allowing the wick to hang from the rib on the inside back wall of the cabinet and positioning the white float into the pocket on the bottom of the cabinet.
- 13) Replace chassis/power pack unit in cabinet, ensuring that the chassis sits correctly on the front, back, and right edges of the cabinet.
- 14) Replace filled water bottle into cabinet, allow to drain, then refill the bottle for maximum running time.
- 15) Replace the bottle cover onto cabinet.
- 16) Plug cord into wall socket.
- 17) Reset humidistat to desired setting.

## **EVAPORATIVE WICK**

- 18) We recommend replacing the wick at least once a season, more often in hard water areas. When the wick appears excessively clogged with mineral deposits, discard it and restore your humidifier's efficiency with a new wick. Wick No. 1045 fits this Series. Contact authorized distributor for replacement.
- 19) NOTE: When replacing the wick, the float rod retainer must be extended prior to inserting the float rod.

# **Summer Storage**

To dry your unit before storage, unplug the cord, remove and empty the water bottle, remove the power pack, and use a clothes peg to clamp the wide circular disk on the float rod to the wick retainer. This will hold the float in an upright position causing the unit to run continuously. Re-assemble the unit, plug it in and turn the humidistat fully clockwise to lock the unit on. Run on any speed until the wick is dry. When your wick and unit have thoroughly dried, remove the clothes peg.

- 1) Clean unit as outlined in Care & Maintenance section.
- 2) Discard the used wick. Install a new wick at the beginning of the next season.
- 3) Do not store with a wet wick or water inside the unit or water bottle, as this could become a potential source of bacteria growth.
- 4) Do not store unit in attic or other high-temperature area.
- 5) Clean humidifier and install new wick before the next season begins.

# Accessories

## EVAPORATIVE WICK

Model 1045.

Replaceable evaporative wick continuously draws up moisture as it filters out mineral deposits. Reduces scale buildup in the unit. The Model 1045 wick includes a float rod retainer, which must be extended prior to use.

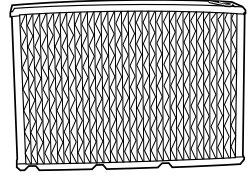

## AIRCARE FILTER (OPTIONAL)

Model 1051

Replaceable two-stage AirCare filter - 3M Filtrete(tm) - removes airborne particles and activated carbon removes odor. This is not standard on all units. It may, however, be added as an accessory to any H12C Humidifier.

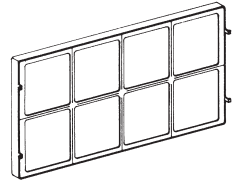



## **ONE-YEAR LIMITED WARRANTY**

The humidifier warranty covers defects in materials and workmanship for a period of one year from date of retail purchase. This warranty applies only to the original purchaser of the product.

Within the first 12 months from date of purchase, Calorex will repair or replace, at its discretion, any defective part of the humidifier covered by this warranty.

This warranty gives you specific legal rights, and you may also have other rights which vary from country to country.

This warranty does not cover damage resulting from misuse or abuse of the humidifier, accidents or alterations to the product, commercial use or damage during shipment. Misuse includes malfunctions caused by negligence in cleaning or parts fouled with mineral deposits due to hard-water conditions. Alterations to the product include the substitution of non-standard components including, but not limited to, wick.

If service becomes necessary, contact the distributor shown below.

### **Calorex Heat Pumps Limited**

**The Causeway, Maldon, Essex CM9 5PU**

Tel NO: +44 (0)1621 856611

Service NO: +44 (0)1621 857171

Fax NO: +44 (0)1621 850871

Email: [sales@calorex.com](mailto:sales@calorex.com)

Website: <http://www.calorex.com>